

FASCO INDUSTRIAL MOTORS

WHEN PERFORMANCE COUNTS...

"NEW" MARATHON RANGE



AVAILABLE UP TO 2000KW

ACCESSORIES PUMPS VENTILATION PRODUCTS 3 PHASE MOTORS EVAPORATIVE COOLER PUMPS FAN DECORATIVE
FAN BLADES FANS ACCESSORIES PUMPS VENTILATION PRODUCTS 3 PHASE MOTORS EVAPORATIVE COOLERS
VENTILATION PRODUCTS FAN BLADES FANS ACCESSORIES PUMPS VENTILATION PRODUCTS 3 PHASE MOTORS
3 PHASE MOTORS EVAPORATIVE COOLER PUMPS VENTILATION PRODUCTS FANS PUMPS VENTILATION PRODUCTS
ACCESSORIES PUMPS VENTILATION PRODUCTS 3 PHASE MOTORS EVAPORATIVE COOLER PUMPS FAN DECORATIVE
FAN BLADES FANS ACCESSORIES PUMPS VENTILATION PRODUCTS 3 PHASE MOTORS EVAPORATIVE COOLER PUMPS

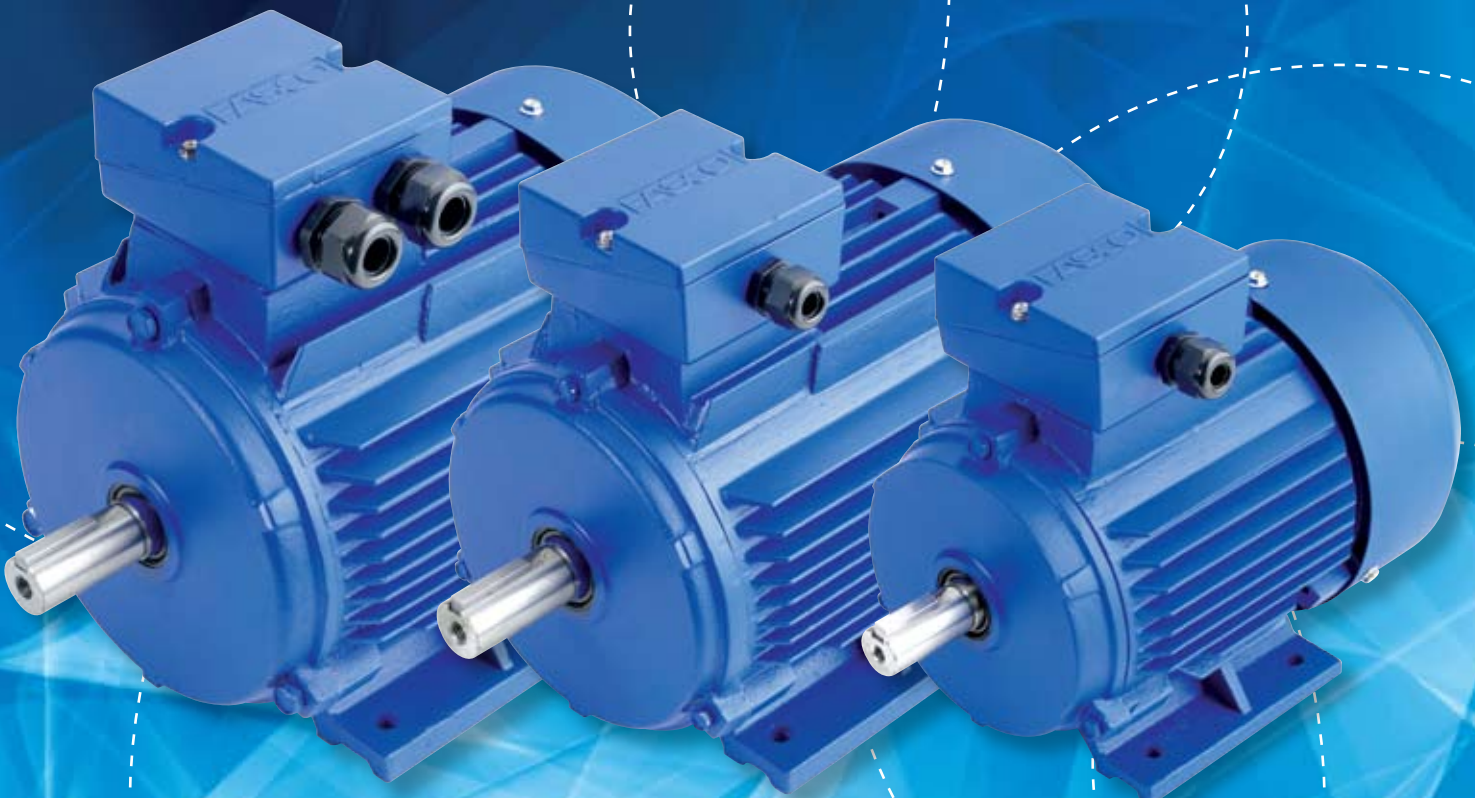

At any given minute, of any given day, people's lives are made easier thanks to the innovative product research and solutions provided by Fasco.



Fasco provides a diverse range of electric motors and blowers with a reputation for product reliability, synonymous with the Fasco name.

Research has shown that half the world's energy is channelled into the operation of three phase electric motors. As a result, Fasco have a solid commitment to developing products that meet higher energy efficiency requirements thus reducing the amount of carbon emissions on our environment.

MEPS efficiency levels

Minimum energy performance standards (MEPS) is a regulatory tool used to increase the average efficiency of a product class.

Since April 2006 MEPS levels for three phase motors became more stringent, meaning higher efficiency levels are now required. Fasco's range of three phase motors all meet these new stringent MEPS efficiency levels, which means guaranteed energy savings over the life of the motor.

The ongoing challenge

Global warming is a very real threat to the world as we know it. Fasco recognises its responsibility to design and manufacture products, conduct operations and provide services in a manner that is responsible to the earth's environment, protective of its natural resources and protective of its employees health and safety. For further information on Fasco's environmental policy contact Fasco.



Quality Endorsed Company
ISO 9001 Lic 21276
SAI Global



Certified Environmental Management
ISO 14001 Lic 20132
SAI Global



For more than a century, Fasco has been designing and manufacturing the industry's most respected line of fractional horsepower electric motors... Now Fasco are proud to introduce their new range of TEFC MEPS2 compliant motors.

In mid 2007 Fasco became part of the Regal Beloit Corporation. Regal Beloit is a leading international manufacturer of electrical and mechanical motion control components. The company has over 17,000 employees and in excess of 70 manufacturing and service distribution facilities world wide. From electric motors and generators to gear reducers, and electronic switchgear, Regal Beloit products are often concealed within, but essential to the function of much of the equipment powering the world. Markets include HVAC, food processing, medical, material handling, petrochemical, construction manufacturing, agricultural and mining to name a few.

Regal Beloit brands include Marathon, Lincoln and Leeson industrial motors. The introduction of these brands into the Australian market place is currently being planned.



Our motors power thousands of products in a diverse range of industries. Our expanding global presence, superior customer service and experienced staff can provide you with the highest quality product. The worldwide Fasco motors group has a combined annual turnover of close to 400 million dollars US.

Here in Asia Pacific we benefit from this combined strength which helps us to ensure market leadership and to provide an unparalleled level of service to our customer base. Today Fasco employees approximately 4,000 people in 5 manufacturing locations across America and Asia Pacific.



FASCO's MEPS 2 Three Phase Induction Motors are, totally enclosed fan cooled (TEFC), induction motors meeting the latest International and Australian design standards.

STANDARDS

- + Design and Manufactured to AS/NZS 1359, IEC34 & IEC72.
- + All motors fully comply with Minimum Energy Performance (MEPS) requirements which are set out in AS/NZS 1359.5-2000.

DUTY RATING

- + Motors are all continuously maximum rated Type – S1.

INVERTER DUTY

- + Motors are suitable for Inverter duty, subject to torque and speed limitations and correct installation of motor and drive.

INSULATION CLASS

- + Class F insulation and B Class delta raise (80K). This design allows the motor to run cooler and increases the thermal margin to ensure longer running life.

STATOR AND WINDINGS

- + High grade insulated cold rolled electro magnetic steel laminations.
- + Windings are random wound double enamelled copper wire, impregnated with a solvent less resin and are tropic proof rated as standard.

WINDINGS PROTECTION

- + Frame sizes 160 and larger are fitted with PTC thermistor protection within the windings (one per phase) with leads terminated in the main terminal box.

DEGREE OF PROTECTION

- + Standard enclosure protection is IP55.

ROTATION

- + All standard motors are suitable for operation in either direction of rotation.

MOUNTING

- + Standard Foot mounted – B3 (IM1001).
- + Foot and Flange mounted – B35 (IM2001).
- + Flange mounted – B5 (IM3001).
- + Foot and C Face mounted – B34 (IM2101).
- + C Face mounted – B14 (IM3601).

CONSTRUCTION (CAST IRON)

- + Cast Iron Frame.
- + Cast Iron Endshields.
- + Cast Iron Terminal Box.
- + Steel Fan cowl.
- + Plastic Fan.

CONSTRUCTION (ALUMINIUM)

- + Aluminium Iron Frame.
- + Aluminium Endshields.
- + Aluminium Terminal Box.
- + Steel Fan cowl.
- + Plastic Fan.

AMBIENT

- + Motors are designed to operate in a maximum ambient of +40°C.

ALTITUDE

- + Motors are designed to operate in a maximum 1000 metres above sea level.

VIBRATION

- + Motors meet limits of vibration severity set out by AS 1359.114-1997 Level N (normal) values related to rotating machinery measured in soft suspension.

NOISE

- + Noise levels comply limits set by AS 1359.109-1998/IEC 60034.9-1997.

ROTOR BALANCING

- + Rotors have been dynamically balanced to According to Class N AS1359.50.
- + Squirrel Cage Rotor – Pressure Aluminium Die Cast and balanced.

SHAFT

- + Standard shaft extension lengths provided with standard key and drilled and tapped hole. Shaft extension run out, concentricity and perpendicular to face of standard flange mount motors comply with normal grade tolerance as specified in AS1359 and IEC 60072-1.

COOLING SYSTEM

- + Total enclosed fan cooled (TEFC) over an externally ribbed frame, with free movement of internal air by rotation of rotor blades.
- + Cooling system according to IC411 of IEC60034-6 and AS1359.106.

FINISH

- + Standard motors have a FASCO Blue paint finish (RAL5010).
- + All casting and steel parts are prime coat of rust-resistant paint.
- + Finishing coat – synthetic paint.

OPERATING PARAMETERS

- + 415V 50Hz to suit Australia power supply.
 - + Star connected for 3KW or less.
 - + 400V Delta/690V Star for 4Kw and above.
- See table 'Operating Parameters' below.

BEARING

- + Standard bearings are lubricated with lithium based roller contact bearing grease, suitable for operation within air temperature range of -20°C to +40°C.
- + For operation outside this temperature range, special lubricants are required, please contact Fasco for further details.
- + Frame 160 and above have Grease Relief system that allows motor to be greased via Regreasing Nipples.

See table 'Bearing - Standard Bearing' below.

TERMINAL BOX

- + Standard Top Mount – Side Mount available on request.
- + Cast Iron terminal box with neoprene gasket between terminal box and motor. A flat gasket under the terminal box lid. Earth connection is mounted within the terminal box.

See table 'Terminal Box - Cable Entries' below.

OPERATING PARAMETERS

SUPPLY V/HZ	RATED SPEED	RATED POWER	RATED CURRENT	RATED TORQUE	LOCKED ROTOR TORQUE	BREAKDOWN TORQUE
380/50	0.90	0.90	1.00	0.90	0.83	0.83
415/50	1.00	1.00	1.00	1.00	1.00	1.00
440/50	1.00	1.00	1.00	1.00	1.10	1.10
415/60	1.20	1.00	1.00	0.83	0.69	0.69
440/60	1.20	1.05	1.00	0.87	0.77	0.77
460/60	1.20	1.10	1.00	0.97	0.85	0.85
480/60	1.20	1.15	1.00	0.96	0.92	0.92

BEARING - STANDARD BEARING

FRAME	DRIVE END	NON DRIVE END
80	6204-2RS	6204-2RS
90	6205-2RS	6205-2RS
100	6206-2RS	6206-2RS
112	6206-2RS	6206-2RS
132	6208-2RS	6208-2RS
160	6209	6209
180	6211	6211
200	6212	6212
225	6213	6213
250	6214	6214
280-2,4	6316	6316
280-6,8	6316	6316
315-2	6316	6316
315-4,6,8	NU319	6319
355-2	6319	6319
355-4,6,8	NU322	6319

TERMINAL BOX - CABLE ENTRIES

FRAME	NUMBER OF ENTRY	ENTRY/PITCH
80/90	2	M24 X 1.5
100/112	2	M24 X 1.5
132	2	M24 X 1.5
160/180	2	M36 X 1.5
200/225	2	M48 X 1.5
250/280	2	M63 X 1.5
315/335	2	M63 X 1.5

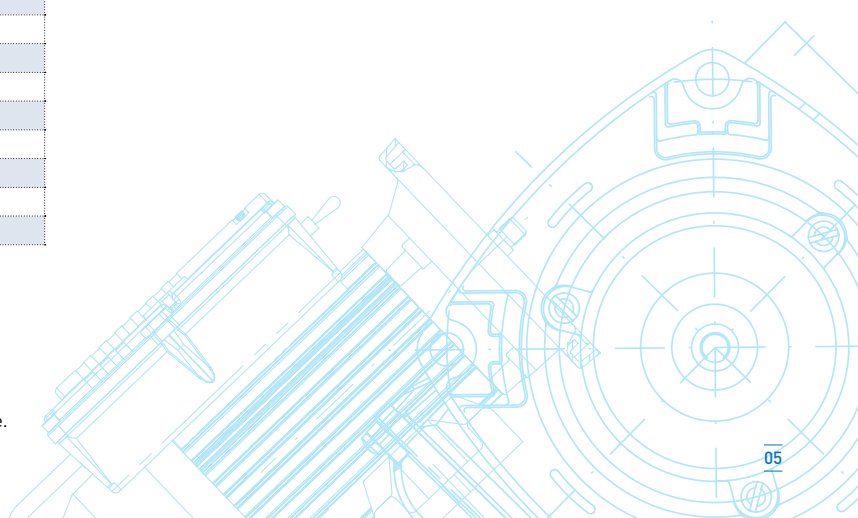

ALUMINIUM 3 PHASE

B3 MOTOR SERIES MS1/FMS2 RANGE

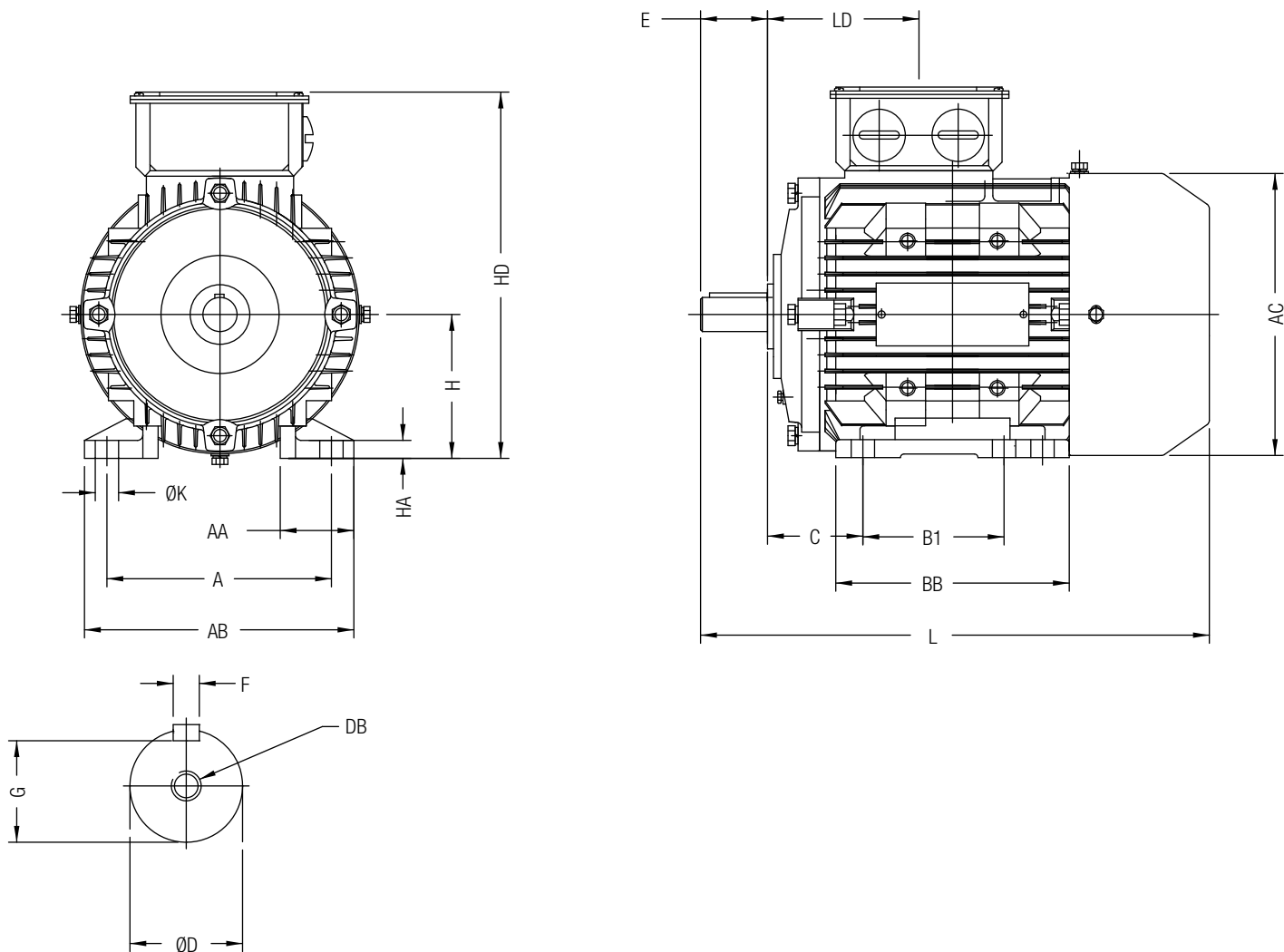

FASCO ALUMINIUM TEFC 3-PHASE INDUCTION MOTORS

FRAME	POLES	A	B1	C	D	DB	E	F	G	H	K	AB	AC (MAX)	HD (MAX)	BB (MAX)	LD	HA	AA	L (MAX)
63*	2,4,6	100	80	40	11	M4	23	4	8.5	63	7	135	122	162	100	58	10.5	34	220
71*	2,4,6	112	90	45	14	M5	30	5	11	71	7	145	138	182	110	72	12.5	34	250
80*	2,4,6	125	100	50	19	M6	40	6	15.5	80	10	155	150	205	125	80	15	34	282
80	2,4,6	125	100	50	19	M6	40	6	15.5	80	10	155	156	205	132	80	10	41	282
90S	2,4,6	140	100	56	24	M8	50	8	20	90	10	168	176	230	140	80	12	47	310
90L	2,4,6	140	125	56	24	M8	50	8	20	90	10	168	176	230	165	80	12	47	335
100L	2,4,6	160	140	63	28	M10	60	8	24	100	12	192	196	250	176	82	12	50	375
112M	2,4,6	190	140	70	28	M10	60	8	24	112	12	222	220	280	180	88	14	60	395
132S	2,4,6	216	140	89	38	M12	80	10	33	132	12	248	260	320	224	95	15	61	465
132M	4,6	216	178	89	38	M12	80	10	33	132	12	248	260	320	224	95	15	61	495

*MS1- Non MEPS 2 Motor. All others FMS2 Range

Design, data, dimensions and specifications are all subject to change without notice.

ALUMINIUM 3 PHASE

B35 (B5) MOTOR SERIES MS1/FMS2 RANGE

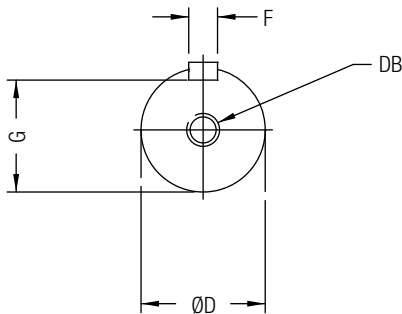
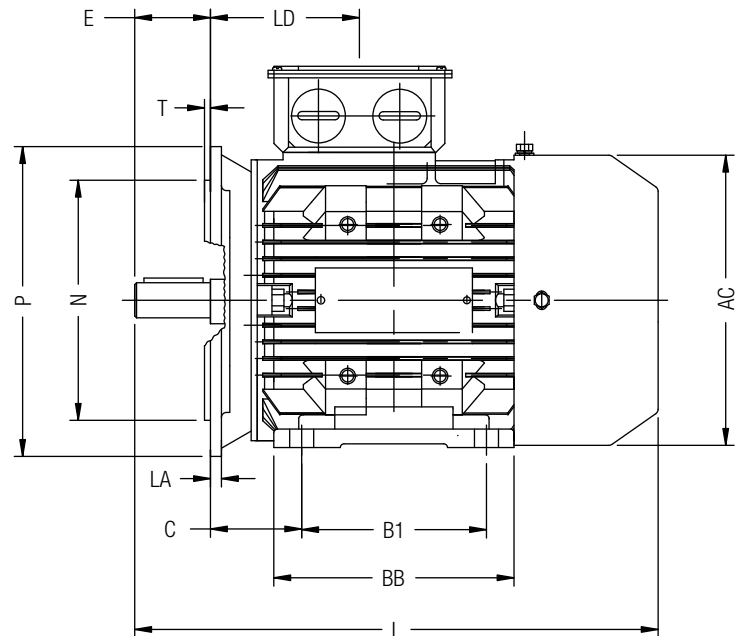
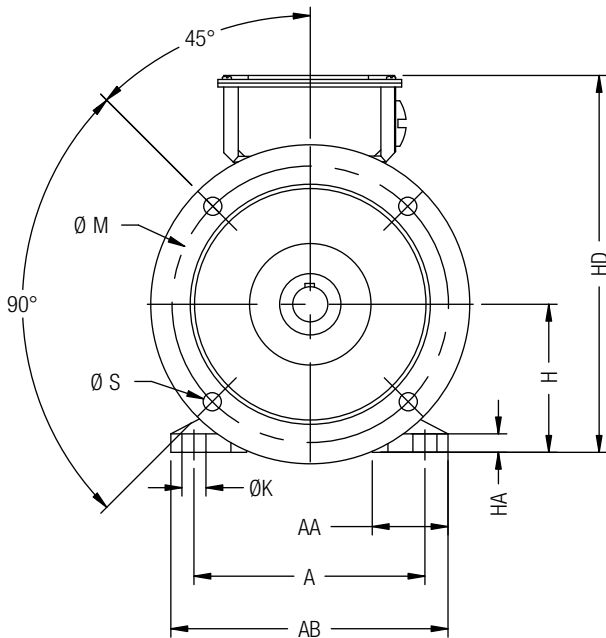

FASCO ALUMINIUM TEFC 3-PHASE INDUCTION MOTORS

FRAME	POLES	A	B1	C	D	DB	E	F	G	H	K	M	N	P	S	T	AB	AC (MAX)	HD (MAX)	BB (MAX)	LD	HA	AA	L (MAX)
63*	2,4,6	100	80	40	11	M4	23	4	8.5	63	7	115	95	140	10	3	135	122	162	100	58	10.5	34	220
71*	2,4,6	112	90	45	14	M5	30	5	11	71	7	130	110	160	10	3.5	145	138	182	110	72	12.5	34	250
80*	2,4,6	125	100	50	19	M6	40	6	15.5	80	10	165	130	200	12	3.5	155	150	205	125	80	15	34	282
80	2,4,6	125	100	50	19	M6	40	6	15.5	80	10	165	130	200	12	3.5	155	156	205	132	80	10	41	282
90S	2,4,6	140	100	56	24	M8	50	8	20	90	10	165	130	200	12	3.5	168	176	230	140	80	12	47	310
90L	2,4,6	140	125	56	24	M8	50	8	20	90	10	165	130	200	12	3.5	168	176	230	165	80	12	47	335
100L	2,4,6	160	140	63	28	M10	60	8	24	100	12	215	180	250	15	4	192	196	250	176	82	12	50	375
112M	2,4,6	190	140	70	28	M10	60	8	24	112	12	215	180	250	15	4	222	220	280	180	88	14	60	395
132S	2,4,6	216	140	89	38	M12	80	10	33	132	12	265	230	300	15	4	248	260	320	224	95	15	61	465
132M	4,6	216	178	89	38	M12	80	10	33	132	12	265	230	300	15	4	248	260	320	224	95	15	61	495

*MS1- Non MEPS 2 Motor. All others FMS2 Range

Design, data, dimensions and specifications are all subject to change without notice.

ALUMINIUM 3 PHASE

B34 (B14A) MOTOR SERIES MS1/FMS2 RANGE

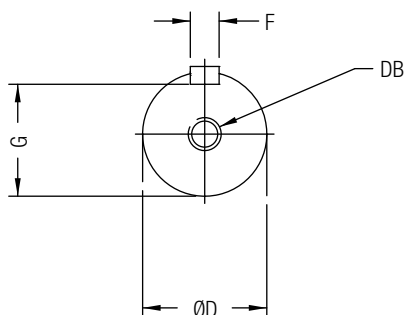
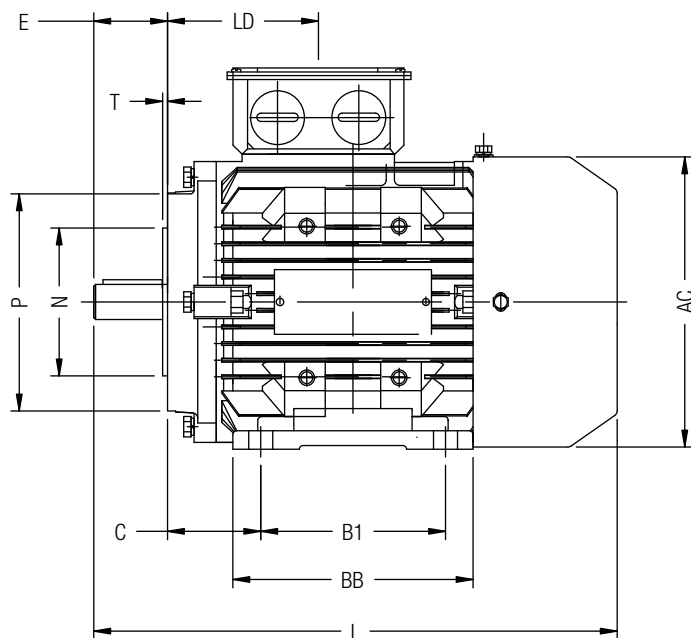
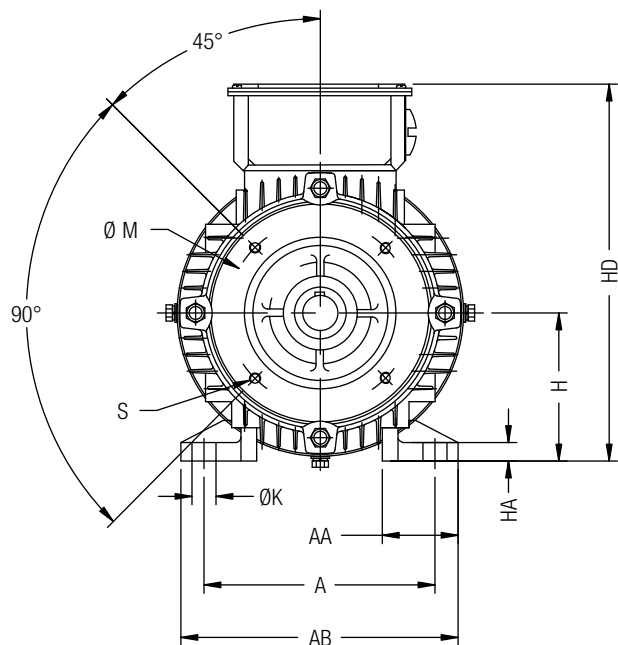

FASCO ALUMINIUM TEFC 3-PHASE INDUCTION MOTORS

FRAME	POLES	A	B1	C	D	DB	E	F	G	H	K	M	N	P	S	T	AB	AC (MAX)	HD (MAX)	BB (MAX)	LD	HA	AA	L (MAX)
63*	2,4,6	100	80	40	11	M4	23	4	8.5	63	7	75	60	90	M5	2.5	135	122	162	100	58	10.5	34	220
71*	2,4,6	112	90	45	14	M5	30	5	11	71	7	85	70	105	M6	2.5	145	138	182	110	72	12.5	34	250
80*	2,4,6	125	100	50	19	M6	40	6	15.5	80	10	100	80	120	M6	3	155	150	205	125	80	15	34	282
80	2,4,6	125	100	50	19	M6	40	6	15.5	80	10	100	80	120	M6	3	155	156	205	132	80	10	41	282
90S	2,4,6	140	100	56	24	M8	50	8	20	90	10	115	95	140	M8	3	168	176	230	140	80	12	47	310
90L	2,4,6	140	125	56	24	M8	50	8	20	90	10	115	95	140	M8	3	168	176	230	165	80	12	47	335
100L	2,4,6	160	140	63	28	M10	60	8	24	100	12	130	110	160	M8	3.5	192	196	250	176	82	12	50	375
112M	2,4,6	190	140	70	28	M10	60	8	24	112	12	130	110	160	M8	3.5	222	220	280	180	88	14	60	395
132S	2,4,6	216	140	89	38	M12	80	10	33	132	12	165	130	200	M10	3.5	248	260	320	224	95	15	61	465
132M	4,6	216	178	89	38	M12	80	10	33	132	12	165	130	200	M10	3.5	248	260	320	224	95	15	61	495

*MS1- Non MEPS 2 Motor. All others FMS2 Range

Design, data, dimensions and specifications are all subject to change without notice.

ALUMINIUM 1 PHASE (240V)

FAL/FAY SERIES

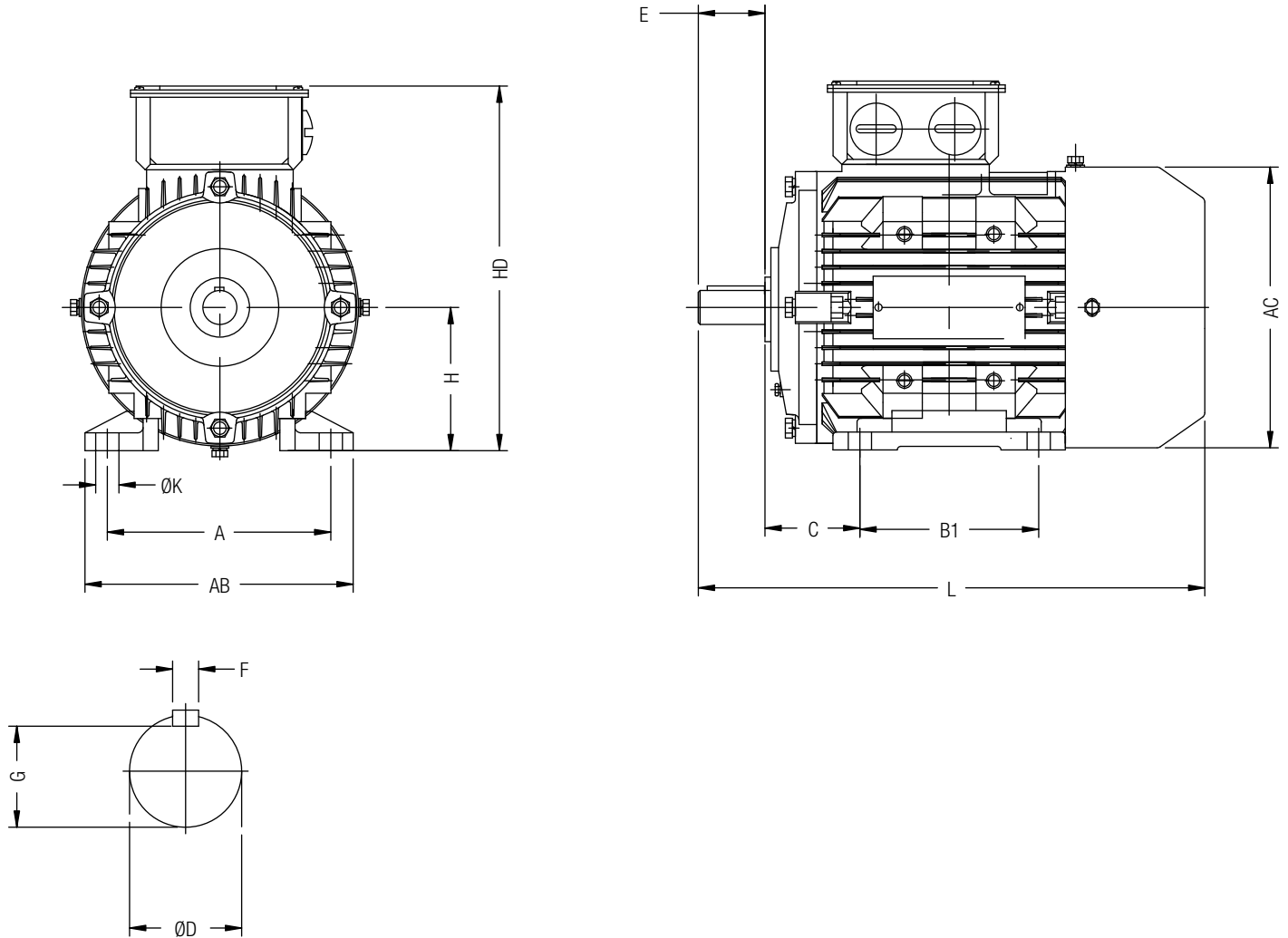

FASCO ALUMINIUM TEFC 240V INDUCTION MOTORS

FRAME	A	B1	C	D	E	F	G	H	K	AB	AC	HD	L
71	112	90	45	14	30	5	11	71	7	137	145	186	255
80	125	100	50	19	40	6	15.5	80	10	156	160	205	295
90S	140	100	56	24	50	8	20	90	10	175	175	230	340
90L	140	125	56	24	50	8	20	90	10	175	175	230	340
100L	160	140	63	28	60	8	24	100	12	190	195	255	385

ALUMINIUM 1 & 3 PHASE

ELECTRICAL DATA MS1/FMS2 RANGE + FAL/FAY RANGE

FASCO ALUMINIUM 3-PHASE ELECTRICAL DATA MS1/FMS2 RANGE

MODEL	FRAME	POLES	OUTPUT - KW	VOLT	HZ	FL AMP	FL PF	FL EFF - %	FL SPEED - RPM	IP
MS1-631-2	63	2	0.18	415	50	0.48	0.80	65.0	2720	55
MS1-632-2	63	2	0.25	415	50	0.63	0.81	68.0	2720	55
MS1-711-2	71	2	0.37	415	50	0.91	0.81	70.0	2740	55
MS1-712-2	71	2	0.55	415	50	1.28	0.82	73.0	2740	55
FMS2-801-2	80	2	0.75	415	50	1.50	0.84	80.7	2845	55
FMS2-802-2	80	2	1.1	415	50	2.20	0.84	82.8	2845	55
FMS2-90S-2	90S	2	1.5	415	50	2.95	0.84	84.1	2855	55
FMS2-90L-2	90L	2	2.2	415	50	4.20	0.85	85.6	2865	55
FMS2-100L-2	100L	2	3	415	50	5.53	0.87	86.7	2865	55
FMS2-112M-2	112M	2	4	415	50	7.30	0.87	87.6	2890	55
FMS2-132S1-2	132S	2	5.5	415	50	9.80	0.88	88.5	2910	55
FMS2-132S2-2	132S	2	7.5	415	50	13.10	0.88	89.5	2910	55
MS1-631-4	63	4	0.12	415	50	0.41	0.72	57.0	1310	55
MS1-632-4	63	4	0.18	415	50	0.57	0.73	60.0	1310	55
MS1-711-4	71	4	0.25	415	50	0.72	0.74	65.0	1330	55
MS1-712-4	71	4	0.37	415	50	1.02	0.75	67.0	1330	55
MS1-801-4	80	4	0.55	415	50	1.44	0.75	74.0	1390	55
FMS2-802-4	80	4	0.75	415	50	1.70	0.73	82.2	1420	55
FMS2-90S-4	90S	4	1.1	415	50	2.28	0.78	83.4	1420	55
FMS2-90L-4	90L	4	1.5	415	50	3.20	0.78	85.0	1425	55
FMS2-100L1-4	100L	4	2.2	415	50	4.54	0.78	86.4	1440	55
FMS2-100L2-4	100L	4	3	415	50	6.12	0.78	87.4	1440	55
FMS2-112M-4	112M	4	4	415	50	8.00	0.82	88.3	1440	55
FMS2-132S-4	132S	4	5.5	415	50	10.30	0.83	89.2	1445	55
FMS2-132M-4	132M	4	7.5	415	50	13.80	0.84	90.1	1445	55
MS1-712-6	71	6	0.25	415	50	0.87	0.68	59.0	850	55
MS1-801-6	80	6	0.37	415	50	1.19	0.70	62.0	890	55
MS1-802-6	80	6	0.55	415	50	1.64	0.72	65.0	890	55
FMS2-90S-6	90S	6	0.75	415	50	1.92	0.70	77.7	930	55
FMS2-90L-6	90L	6	1.1	415	50	2.66	0.72	79.9	930	55
FMS2-100L-6	100L	6	1.5	415	50	3.46	0.74	81.5	945	55
FMS2-112M-6	112M	6	2.2	415	50	5.00	0.74	83.4	945	55
FMS2-132S-6	132S	6	3	415	50	6.50	0.76	84.9	960	55
FMS2-132M1-6	132M	6	4	415	50	8.40	0.76	86.1	960	55
FMS2-132M2-6	132M	6	5.5	415	50	11.20	0.77	87.4	960	55

FASCO ALUMINIUM SINGLE PHASE ELECTRICAL DATA (240V) FAL/FAY RANGE

FAL/SERIES IP55, Class F insulation, 240 Volts 50 Hz, Aluminium Frame Motor, Endshield /Flanges TEFC IC0411, Continuous S1 Duty, CSCR (Capacitor Start, Capacitor Run) Normal Starting Torque . Manual Reset Overload Protector fitted

MODEL	FRAME	POLE	OUTPUT POWER	VOLT	HZ	FL AMP	FL PF	FL EFF - %	SPEED - RPM	INSULATION CLASS	PROTECTION CLASS
FAL-711-2	71	2	0.37	240	50	2.7	0.92	67	2800	F	IP44
FAL-712-2	71	2	0.55	240	50	3.8	0.92	70	2800	F	IP44
FAL-801-2	80	2	0.75	240	50	5.1	0.92	72	2800	F	IP44
FAL-802-2	80	2	1.1	240	50	7	0.95	75	2800	F	IP44
FAL-90S-2	90S	2	1.5	240	50	9.4	0.95	76	2800	F	IP44
FAL-90L-2	90L	2	2.2	240	50	13.6	0.95	77	2800	F	IP44
FAL-100L-2	100L	2	3	240	50	18.2	0.95	79	2800	F	IP44
FAL-711-4	71	4	0.25	240	50	2	0.92	62	1400	F	IP44
FAL-712-4	71	4	0.37	240	50	2.9	0.92	65	1400	F	IP44
FAL-801-4	80	4	0.55	240	50	4.2	0.92	68	1400	F	IP44
FAL-802-4	80	4	0.75	240	50	5.4	0.92	71	1400	F	IP44
FAL-90S-4	90S	4	1.1	240	50	7.4	0.95	73	1400	F	IP44
FAL-90L-4	90L	4	1.5	240	50	9.8	0.95	75	1400	F	IP44
FAL-100L1-4	100L	4	2.2	240	50	14	0.95	76	1400	F	IP44
FAL-100L2-4	100L	4	3	240	50	18.5	0.95	76	1400	F	IP44

FAY/SERIES IP55, Class F insulation, 240 Volts 50 Hz, Aluminium Frame Motor, Endshield /Flanges TEFC IC0411, Continuous S1 Duty, CSR (Capacitor Start Run) Fan or Centrifugal Pump Loads. Manual Reset Overload Protector fitted

MODEL	FRAME	POLE	OUTPUT POWER	VOLT	HZ	FL AMP	FL PF	FL EFF - %	SPEED - RPM	INSULATION CLASS	PROTECTION CLASS
FAY-711-2	71	2	0.25	240	50	1.87	0.92	63			
FAY-712-2	71	2	0.37	240	50	2.7	0.92	67	2800	F	IP44
FAY-713-2	71	2	0.55	240	50	3.8	0.92	70	2800	F	IP44
FAY-801-2	80	2	0.75	240	50	5.1	0.92	72	2800	F	IP44
FAY-802-2	80	2	1.1	240	50	7	0.95	75	2800	F	IP44
FAY-90S-2	90S	2	1.5	240	50	9.4	0.95	76	2800	F	IP44
FAY-90L-2	90L	2	2.2	240	50	13.6	0.95	77	2800	F	IP44
FAY-711-4	71	4	0.25	240	50	2	0.92	61	1400	F	IP44
FAY-712-4	71	4	0.37	240	50	2.9	0.92	62	1400	F	IP44
FAY-801-4	80	4	0.55	240	50	4.2	0.92	64	1400	F	IP44
FAY-802-4	80	4	0.75	240	50	5.4	0.92	68	1400	F	IP44
FAY-90S-4	90S	4	1.1	240	50	7.4	0.95	71	1400	F	IP44
FAY-90L-4	90L	4	1.5	240	50	9.8	0.95	73	1400	F	IP44

Design, data, dimensions and specifications are all subject to change without notice.

CAST IRON 3 PHASE

ELECTRICAL DATA

FASCO CAST IRON ELECTRICAL DATA – 2 POLE

MODEL	FRAME	POLES	POWER OUTPUT	VOLTS	HERIZ	AMPS	POWER FACTOR	EFFICIENCY	RPM	CLASS
FY2-631-2	63	2	0.18	415	50	0.48	0.80	65.0	2720	F
FY2-632-2	63	2	0.25	415	50	0.63	0.81	68.0	2720	F
FY2-711-2	71	2	0.37	415	50	0.91	0.81	70.0	2740	F
FY2-712-2	71	2	0.55	415	50	1.28	0.82	73.0	2740	F
Y2HE-801-2	80	2	0.75	415	50	1.50	0.84	80.7	2845	F
Y2HE-802-2	80	2	1.1	415	50	2.20	0.84	82.8	2845	F
Y2HE-90S-2	90S	2	1.5	415	50	2.95	0.84	84.1	2855	F
Y2HE-90L-2	90L	2	2.2	415	50	4.20	0.85	85.6	2865	F
Y2HE-100L-2	100L	2	3	415	50	5.53	0.87	86.7	2865	F
Y2HE-112M-2	112M	2	4	415	50	7.30	0.87	87.6	2890	F
Y2HE-132S1-2	132S	2	5.5	415	50	9.8	0.88	89.1	2900	F
Y2HE-132S2-2	132S	2	7.5	415	50	13.1	0.88	90.3	2900	F
Y2HE-160M1-2	160M	2	11	415	50	19	0.89	90.6	2940	F
Y2HE-160M2-2	160M	2	15	415	50	25.9	0.89	91.3	2940	F
Y2HE-160L-2	160L	2	18.5	415	50	31.2	0.89	91.8	2940	F
Y2HE-180M-2	180M	2	22	415	50	37.2	0.90	92.2	2950	F
Y2HE-200L1-2	200L	2	30	415	50	50.2	0.89	92.9	2965	F
Y2HE-200L2-2	200L	2	37	415	50	61.9	0.89	93.3	2965	F
Y2HE-225M-2	225M	2	45	415	50	75.2	0.90	93.7	2965	F
Y2HE-250M-2	250M	2	55	415	50	91.4	0.89	94.0	2970	F
Y2HE-280S-2	280S	2	75	415	50	122.6	0.90	94.6	2975	F
Y2HE-280M-2	280M	2	90	415	50	147.2	0.90	94.8	2975	F
Y2HE-315S-2	315S	2	110	415	50	178.5	0.91	95.0	2975	F
Y2HE-315M-2	315M	2	132	415	50	213.1	0.91	95.4	2975	F
Y2HE-315L1-2	315L	2	160	415	50	256.9	0.91	95.4	2975	F
Y2HE-315L2-2	315L	2	200	415	50	320	0.91	95.4	2970	F
Y2HE-355M-2	355M	2	250	415	50	397	0.92	95.3	2980	F
Y2HE-355L1-2	355L	2	280	415	50	443	0.92	95.6	2980	F
Y2HE-355L2-2	355L	2	315	415	50	498	0.92	95.6	2980	F

FASCO CAST IRON ELECTRICAL DATA – 4 POLE

MODEL	FRAME	POLES	POWER OUTPUT	VOLTS	HERIZ	AMPS	POWER FACTOR	EFFICIENCY	RPM	CLASS
FY2-631-4	63	4	0.12	415	50	0.41	0.72	57.0	1310	F
FY2-632-4	63	4	0.18	415	50	0.57	0.73	60.0	1310	F
FY2-711-4	71	4	0.25	415	50	0.72	0.74	65.0	1330	F
FY2-712-4	71	4	0.37	415	50	1.02	0.75	67.0	1330	F
FY2-801-4	80	4	0.55	415	50	1.44	0.75	74.0	1390	F
Y2HE-802-4	80	4	0.75	415	50	1.70	0.73	82.2	1420	F
Y2HE-90S-4	90S	4	1.1	415	50	2.28	0.78	83.4	1420	F
Y2HE-90L-4	90L	4	1.5	415	50	3.20	0.78	85.0	1425	F
Y2HE-100L1-4	100L	4	2.2	415	50	4.54	0.78	86.4	1440	F
Y2HE-100L2-4	100L	4	3	415	50	6.12	0.78	87.4	1440	F
Y2HE-112M-4	112M	4	4	415	50	8.00	0.82	88.3	1440	F
Y2HE-132S-4	132S	4	5.5	415	50	10.2	0.85	89.2	1460	F
Y2HE-132M-4	132M	4	7.5	415	50	13.6	0.85	90.1	1460	F
Y2HE-160M-4	160M	4	11	415	50	20	0.85	91	1470	F
Y2HE-160L-4	160L	4	15	415	50	26.7	0.86	91.8	1470	F
Y2HE-180M-4	180M	4	18.5	415	50	32.2	0.86	92.2	1470	F
Y2HE-180L-4	180L	4	22	415	50	38.4	0.86	92.6	1470	F
Y2HE-200L-4	200L	4	30	415	50	52	0.86	93.2	1475	F
Y2HE-225S-4	225S	4	37	415	50	63.2	0.87	93.6	1480	F
Y2HE-225M-4	225M	4	45	415	50	76.5	0.87	93.9	1480	F
Y2HE-250M-4	250M	4	55	415	50	93	0.87	94.2	1480	F
Y2HE-280S-4	280S	4	75	415	50	126.6	0.88	94.7	1485	F
Y2HE-280M-4	280M	4	90	415	50	151.5	0.88	95	1485	F
Y2HE-315S-4	315S	4	110	415	50	182.3	0.88	95.4	1485	F
Y2HE-315M-4	315M	4	132	415	50	218.7	0.88	95.4	1485	F
Y2HE-315L1-4	315L	4	160	415	50	262	0.88	95.4	1485	F
Y2HE-315L2-4	315L	4	200	415	50	327	0.88	95.7	1485	F
Y2HE-355M1-4	355M	4	220	415	50	365	0.9	95.3	1480	F
Y2HE-355M2-4	355M	4	250	415	50	415	0.88	95.3	1480	F
Y2HE-355L1-4	355L	4	280	415	50	458	0.89	95.6	1480	F
Y2HE-355L2-4	355L	4	315	415	50	515	0.89	95.6	1480	F

Design, data, dimensions and specifications are all subject to change without notice.

FASCO CAST IRON ELECTRICAL DATA – 6 POLE

MODEL	FRAME	POLES	POWER OUTPUT	VOLTS	HERIZ	AMPS	POWER FACTOR	EFFICIENCY	RPM	CLASS
FY2-712-6	71	6	0.25	415	50	0.87	0.68	59	850	F
FY2-801-6	80	6	0.37	415	50	1.19	0.7	62	890	F
FY2-802-6	80	6	0.55	415	50	1.64	0.72	65	890	F
Y2HE-90S-6	90S	6	0.75	415	50	1.92	0.7	77.7	930	F
Y2HE-90L-6	90L	6	1.1	415	50	2.66	0.72	79.9	930	F
Y2HE-100L-6	100L	6	1.5	415	50	3.46	0.74	81.5	945	F
Y2HE-112M-6	112M	6	2.2	415	50	5.00	0.74	83.4	945	F
Y2HE-132S-6	132S	6	3	415	50	6.4	0.76	84.9	965	F
Y2HE-132M1-6	132M	6	4	415	50	8.5	0.76	86.1	970	F
Y2HE-132M2-6	132M	6	5.5	415	50	11.3	0.77	87.4	970	F
Y2HE-160M-6	160M	6	7.5	415	50	15.1	0.78	88.5	975	F
Y2HE-160L-6	160L	6	11	415	50	21.8	0.78	89.8	975	F
Y2HE-180L-6	180L	6	15	415	50	28	0.81	90.7	980	F
Y2HE-200L1-6	200L	6	18.5	415	50	34.6	0.81	91.3	980	F
Y2HE-200L2-6	200L	6	22	415	50	40	0.83	91.8	980	F
Y2HE-225M-6	225M	6	30	415	50	53.2	0.84	92.5	985	F
Y2HE-250M-6	250M	6	37	415	50	64.5	0.85	93	985	F
Y2HE-280S-6	280S	6	45	415	50	77.4	0.86	93.5	990	F
Y2HE-280M-6	280M	6	55	415	50	94.3	0.86	93.9	990	F
Y2HE-315S-6	315S	6	75	415	50	128.5	0.86	94.4	990	F
Y2HE-315M-6	315M	6	90	415	50	153.6	0.86	94.8	990	F
Y2HE-315L1-6	315L	6	110	415	50	187.1	0.86	95.1	990	F
Y2HE-315L2-6	315L	6	132	415	50	221	0.86	95.4	990	F
Y2HE-355M1-6	355M	6	160	415	50	266.3	0.88	94.9	990	F
Y2HE-355M3-6	355M	6	200	415	50	364	0.88	94.9	990	F
Y2HE-355L1-6	355L	6	220	415	50	397	0.88	94.9	990	F
Y2HE-355L2-6	355L	6	250	415	50	454	0.88	94.9	990	F

FASCO CAST IRON ELECTRICAL DATA – 8 POLE

MODEL	FRAME	POLES	POWER OUTPUT	VOLTS	HERIZ	AMPS	POWER FACTOR	EFFICIENCY	RPM	CLASS
Y2HE-132S-8	132S	8	2.2	415	50	5.20	0.71	80.9	710	F
Y2HE-132M-8	132M	8	3	415	50	7.1	0.71	82.7	710	F
Y2HE-160M1-8	160M	8	4	415	50	8.9	0.73	84.2	715	F
Y2HE-160M2-8	160M	8	5.5	415	50	11.9	0.74	85.8	715	F
Y2HE-160L-8	160L	8	7.5	415	50	16.1	0.74	87.2	720	F
Y2HE-180L-8	180L	8	11	415	50	22.7	0.75	88.8	730	F
Y2HE-200L-8	200L	8	15	415	50	30.3	0.76	90	730	F
Y2HE-225S-8	225S	8	18.5	415	50	36.8	0.76	90.7	735	F
Y2HE-225M-8	225M	8	22	415	50	42.5	0.78	91.2	735	F
Y2HE-250M-8	250M	8	30	415	50	56.6	0.79	92.1	735	F
Y2HE-280S-8	280S	8	37	415	50	69.7	0.79	92.7	740	F
Y2HE-280M-8	280M	8	45	415	50	84.5	0.79	93.2	740	F
Y2HE-315S-8	315S	8	55	415	50	102.1	0.8	93.7	740	F
Y2HE-315L1-8	315L	8	90	415	50	163.2	0.81	94.7	740	F
Y2HE-315L2-8	315L	8	110	415	50	196.2	0.82	95.1	740	F
Y2HE-355M1-8	355M	8	132	415	50	231.9	0.83	95.4	740	F
Y2HE-355M2-8	355M	8	160	415	50	276.9	0.84	95.7	740	F
Y2HE-355L2-8	355L	8	200	415	50	346.1	0.84	95.7	740	F

CAST IRON 3 PHASE

B3 SERIES FY2/Y2HE RANGE

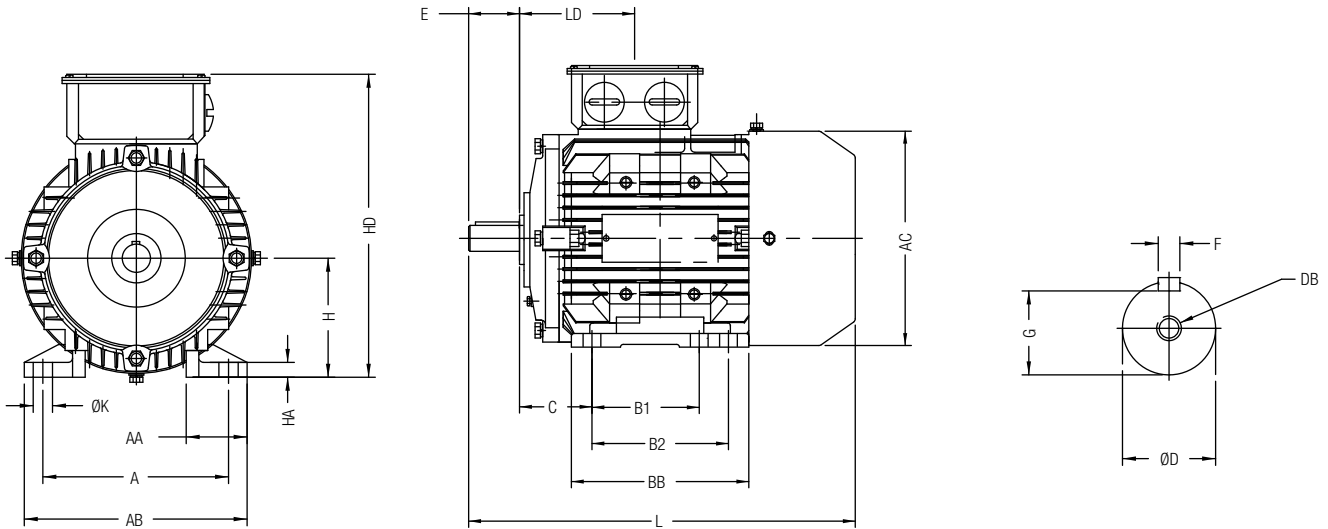

FASCO CAST IRON TEFC 3-PHASE INDUCTION MOTORS

FRAME	POLES	A	B1	B2	C	D	DB	E	F	G	H	K	AB	AC (MAX)	HD (MAX)	BB (MAX)	LD	HA	AA	L (MAX)
63	2,4,6	100	80	-	40	11	M4	23	4	8.5	63	7	135	126	180	110	67	8	34	225
71	2,4,6	112	90	-	45	14	M5	30	5	11	71	7	150	142	195	120	72	10	37	260
80	2,4,6	125	100	-	50	19	M6	40	6	15.5	80	10	165	160	214	132	78	10	41	295
90S	2,4,6	140	100	-	56	24	M8	50	8	20	90	10	180	180	250	140	80	12	47	315
90L	2,4,6	140	125	-	56	24	M8	50	8	20	90	10	180	180	250	165	80	12	47	340
100L	2,4,6	160	140	-	63	28	M10	60	8	24	100	12	205	200	270	176	82	12	50	385
112M	2,4,6	190	140	-	70	28	M10	60	8	24	112	12	230	224	300	180	88	14	60	400
132S	2,4,6,8	216	140	-	89	38	M12	80	10	33	132	12	270	264	345	230	99	18	55	510
132M	4,6,8	216	178	-	89	38	M12	80	10	33.0	132	12	270	264	345	230	99	18	55	510
160M	2,4,6,8	254	210	-	108	42	M16	110	12	37	160	15	320	320	435	304	149	20	65	655
160L	2,4,6,8	254	254	-	108	42	M16	110	12	37	160	15	320	320	435	304	149	20	65	655
180M	2,4	279	241	-	121	48	M16	110	14	42.5	180	15	355	360	465	349	161	22	70	720
180L	4,6,8	279	279	-	121	48	M16	110	14	42.5	180	15	355	360	465	349	161	22	70	720
200L	2,4,6,8	318	305	-	133	55	M20	110	16	49	200	19	395	400	525	375	186	25	70	780
225S	4,8	356	286	-	149	60	M20	140	18	53.0	225	18.5	435	450	570	375	189	28	75	820
225M	2	356	311	-	149	55	M20	110	16	49	225	18.5	435	450	570	400	189	28	75	815
225M	4,6,8	356	311	-	149	60	M20	140	18	53.0	225	18.5	435	450	570	400	189	28	75	845
250M	2	406	349	-	168	60	M20	140	18	53	250	24	490	500	635	450	207	30	80	920
250M	4,6,8	406	349	-	168	65	M20	140	18	58.0	250	24	490	500	635	450	207	30	80	920
280S	2	457	368	-	190	65	M20	140	18	58	280	24	550	560	698	485	215.5	35	85	980
280S	4,6,8	457	368	-	190	75	M20	140	20	67.5	280	24	550	560	698	485	215.5	35	85	980
280M	2	457	419	-	190	65	M20	140	18	58	280	24	550	560	698	536	207	35	85	1032
280M	4,6,8	457	419	-	190	75	M20	140	20	67.5	280	24	550	560	698	536	207	35	85	1032
315S	2	508	406	-	216	65	M20	140	18	58	315	28	630	630	885	570	257	45	120	1200
315S	4,6,8	508	406	-	216	80	M20	170	22	71.0	315	28	630	630	885	570	257	45	120	1235
315M	2	508	457	-	216	65	M20	140	18	58	315	28	630	630	885	680	257	45	120	1295
315M	4,6	508	457	-	216	80	M20	170	22	71.0	315	28	630	630	885	680	257	45	120	1350
315L	2	508	508	-	216	65	M20	140	18	58	315	28	630	630	885	680	257	45	120	1295
315L	4,6,8	508	508	-	216	80	M20	170	22	71.0	315	28	630	630	885	680	257	45	120	1345
355M	2	610	560	630	254	75	M24	140	20	67.5	355	35	730	710	1065	760	272	52	120	1495
355M	4,6,8	610	560	630	254	95	M24	170	25	86.0	355	35	730	710	1065	760	272	52	120	1525
355L	2	610	560	630	254	75	M24	140	20	67.5	355	35	730	710	1065	760	272	52	120	1495
355L	4,6,8	610	560	630	254	95	M24	170	25	86.0	355	35	730	710	1065	760	272	52	120	1525

Design, data, dimensions and specifications are all subject to change without notice. | *FY2- Non MEPS 2 Motor. All others Y2HE Range

CAST IRON 3 PHASE

B35 (B5) SERIES FY2/Y2HE RANGE

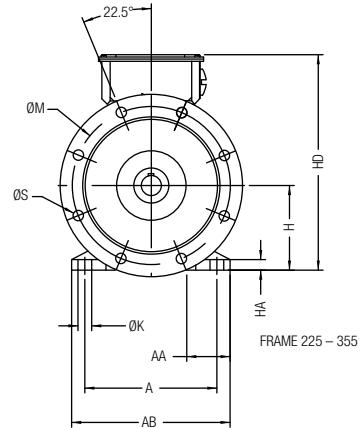
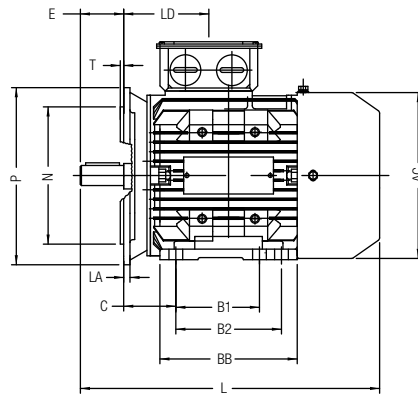
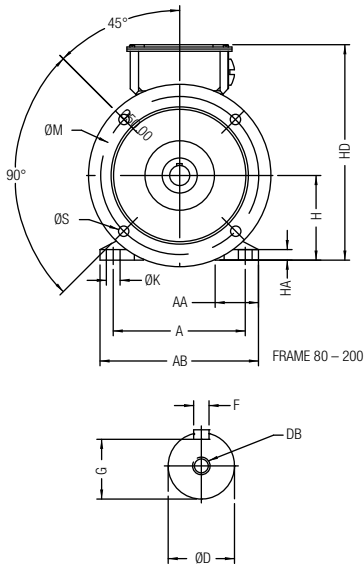

FASCO CAST IRON TEFC 3-PHASE INDUCTION MOTORS

FRAME	POLES	A	B1	B2	C	D	DB	E	F	G	H	K	LA	M	N	P	S	T	AB	AC (MAX)	HD (MAX)	BB (MAX)	LD	HA	AA	L (MAX)
63	2,4,6	100	80	-	40	11	M4	23	4	8.5	63	7	-	115	95	140	10	3	135	126	180	110	67	8	34	225
71	2,4,6	112	90	-	45	14	M5	30	5	11	71	7	-	130	110	160	10	3.5	150	142	195	120	72	10	37	260
80	2,4,6	125	100	-	50	19	M6	40	6	15.5	80	10	10	165	130	200	12	3.5	165	160	214	132	78	10	41	295
90S	2,4,6	140	100	-	56	24	M8	50	8	20	90	10	10	165	130	200	12	3.5	180	180	250	140	80	12	47	315
90L	2,4,6	140	125	-	56	24	M8	50	8	20	90	10	10	165	130	200	12	3.5	180	180	250	165	80	12	47	340
100L	2,4,6	160	140	-	63	28	M10	60	8	24	100	12	12	215	180	250	15	4	205	200	270	176	82	12	50	385
112M	2,4,6	190	140	-	70	28	M10	60	8	24	112	12	12	215	180	250	15	4	230	224	300	180	88	14	60	400
132S	2,4,6,8	216	140	-	89	38	M12	80	10	33	132	12	14	265	230	300	15	4	270	264	345	230	99	18	55	510
132M	4,6,8	216	178	-	89	38	M12	80	10	33.0	132	12	14	265	230	300	15	4	270	264	345	230	99	18	55	510
160M	2,4,6,8	254	210	-	108	42	M16	110	12	37	160	15	15	300	250	350	19	5	320	320	435	304	149	20	65	655
160L	2,4,6,8	254	254	-	108	42	M16	110	12	37	160	15	15	300	250	350	19	5	320	320	435	304	149	20	65	655
180M	2,4	279	241	-	121	48	M16	110	14	42.5	180	15	15	300	250	350	19	5	355	360	465	349	161	22	70	720
180L	4,6,8	279	279	-	121	48	M16	110	14	42.5	180	15	15	300	250	350	19	5	355	360	465	349	161	22	70	720
200L	2,4,6,8	318	305	-	133	55	M20	110	16	49	200	19	17	350	300	400	19	5	395	400	525	375	186	25	70	780
225S	4,8	356	286	-	149	60	M20	140	18	53.0	225	18.5	20	400	350	450	18.5	5	435	450	570	375	189	28	75	820
225M	2	356	311	-	149	55	M20	110	16	49	225	18.5	20	400	350	450	18.5	5	435	450	570	400	189	28	75	815
225M	4,6,8	356	311	-	149	60	M20	140	18	53.0	225	18.5	20	400	350	450	18.5	5	435	450	570	400	189	28	75	845
250M	2	406	349	-	168	60	M20	140	18	53	250	24	22	500	450	550	19	5	490	500	635	450	207	30	80	920
250M	4,6,8	406	349	-	168	65	M20	140	18	58.0	250	24	22	500	450	550	19	5	490	500	635	450	207	30	80	920
280S	2	457	368	-	190	65	M20	140	18	58	280	24	22	500	450	550	19	5	550	560	698	485	215.5	35	85	980
280S	4,6,8	457	368	-	190	75	M20	140	20	67.5	280	24	22	500	450	550	19	5	550	560	698	485	215.5	35	85	980
280M	2	457	419	-	190	65	M20	140	18	58	280	24	22	500	450	550	19	5	550	560	698	536	207	35	85	1032
280M	4,6,8	457	419	-	190	75	M20	140	20	67.5	280	24	22	500	450	550	19	5	550	560	698	536	207	35	85	1032
315S	2	508	406	-	216	65	M20	140	18	58	315	28	22	600	550	660	24	5	630	630	885	570	257	45	120	1200
315S	4,6,8	508	406	-	216	80	M20	170	22	71.0	315	28	22	600	550	660	24	5	630	630	885	570	257	45	120	1235
315M	2	508	457	-	216	65	M20	140	18	58	315	28	25	740	680	800	24	6	630	630	885	680	257	45	120	1295
315M	4,6	508	457	-	216	80	M20	170	22	71.0	315	28	22	600	550	660	24	5	630	630	885	680	257	45	120	1350
315L	2	508	508	-	216	65	M20	140	18	58	315	28	22	600	550	660	24	5	630	630	885	680	257	45	120	1295
315L	4,6,8	508	508	-	216	80	M20	170	22	71.0	315	28	22	600	550	660	24	5	630	630	885	680	257	45	120	1345
355M	2	610	560	630	254	75	M24	140	20	67.5	355	35	25	740	680	800	24	6	730	710	1065	760	272	52	120	1495
355M	4,6,8	610	560	630	254	95	M24	170	25	86.0	355	35	25	740	680	800	24	6	730	710	1065	760	272	52	120	1525
355L	2	610	560	630	254	75	M24	140	20	67.5	355	35	25	740	680	800	24	6	730	710	1065	760	272	52	120	1495
355L	4,6,8	610	560	630	254	95	M24	170	25	86.0	355	35	25	740	680	800	24	6	730	710	1065	760	272	52	120	1525

CAST IRON 3 PHASE

B34 (B14A) SERIES FY2/Y2HE RANGE

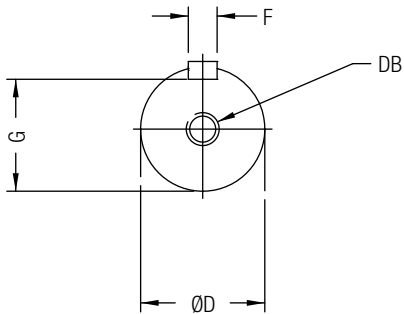
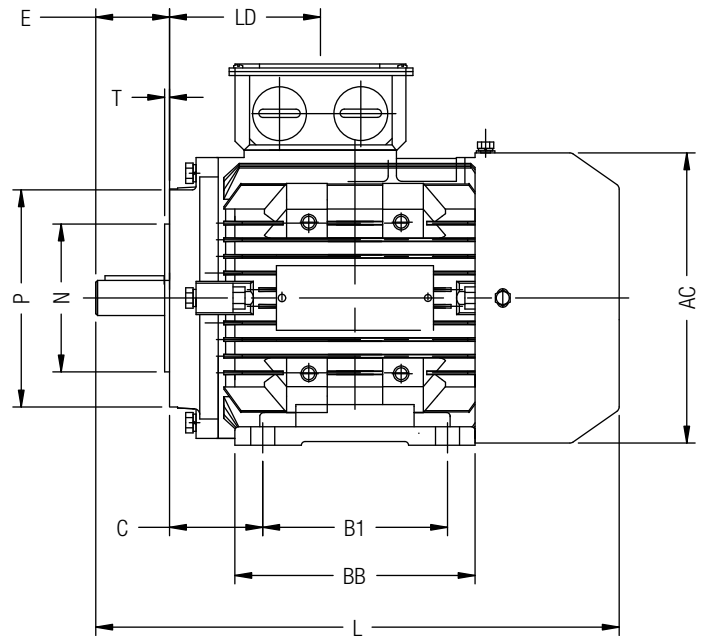
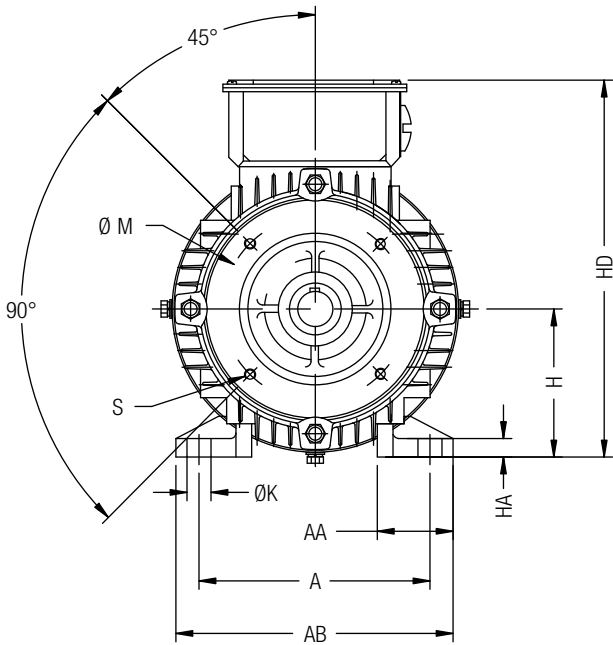

FASCO CAST IRON TEFC 3-PHASE INDUCTION MOTORS

FRAME	POLES	A	B1	C	D	DB	E	F	G	H	K	M	N	P	S	T	AB	AC (MAX)	HD (MAX)	BB (MAX)	LD	HA	AA	L (MAX)
63	2,4,6	100	80	40	11	M4	23	4	8.5	63	7	75	60	90	M5	2.5	135	126	180	110	67	8	34	225
71	2,4,6	112	90	45	14	M5	30	5	11	71	7	85	70	105	M6	2.5	150	142	195	120	72	10	37	260
80	2,4,6	125	100	50	19	M6	40	6	15.5	80	10	100	80	120	M6	3	165	160	214	132	78	10	41	295
90S	2,4,6	140	100	56	24	M8	50	8	20	90	10	115	95	140	M8	3	180	180	250	140	80	12	47	315
90L	2,4,6	140	125	56	24	M8	50	8	20	90	10	115	95	140	M8	3	180	180	250	165	80	12	47	340
100L	2,4,6	160	140	63	28	M10	60	8	24	100	12	130	110	160	M8	3.5	205	200	270	176	82	12	50	385
112M	2,4,6	190	140	70	28	M10	60	8	24	112	12	130	110	160	M8	3.5	230	224	300	180	88	14	60	400



XRH POWER DRIVE high voltage induction motors are perfectly engineered according to customer requirements and applications. Motor design to meet IEC60034 & 60072



CAST IRON CONSTRUCTION

OVERVIEW

Total enclosed cast iron construction rib-cooled for rigidity and reduced vibration, VPI (Vacuum Pressure impregnated) insulation. All motors are provided with SPM (Shock Pulse Monitoring)-nipples to enable user to measure bearing vibration as part of a planned maintenance program as standard on both ends of the motor. Thus the condition of the bearings can be checked easily while the motor is running. Provisions for resistance temperature detectors (RTD) are standard.

KEY FEATURES

- + IEC Frame 355 to 560
- + 1KV ,3.3KV, 6.6KV & 11KV
- + 100 to 2000KW
- + TEFC IC411 Cooling
- + IP54 (IP55 on Request)
- + Mounting IMB3 (IMB35, IMV1 on request)
- + Insulated Bearing available on request
- + Shaft Grounding on request

MODULAR CONSTRUCTION

OVERVIEW

Modular induction motors have been designed to allow air-to water and air-to-air cooling, Protection classes range from IP24 to IP55. VPI (Vacuum Pressure impregnated) insulation, SPM nipples and RTD Platinum is the standard element material but copper is also available. VSD (Variable Speed Drive) applications with shaft grounding available.

KEY FEATURES

- + IEC Frame 355 to 630
- + 3.3KV, 6.6KV & 11KV
- + 100KW to 2000KW
- + TEFC IC611 or IC01 Cooling
- + IP54 (IP55 on Request)
- + Mounting IMB3 (IMB35, IMV1 on request)
- + Insulated Bearing available on request
- + Shaft Grounding on request

XR POWER DRIVE

OVERVIEW

Cast iron construction with low vibration and low noise design. Motor fitted with SPM vibration sensors, PTC (Positive Temperature Coefficient) Thermistors (one per phase), anti -condensation heaters, Key installation for pumping station – raw water & irrigation, waste water, transmission drive/conveyors and similar applications

KEY FEATURES

- + IEC Frame 355 to 560
- + 415V/719V
- + 200KW – 1200KW
- + TEFC IC411 Cooling
- + IP55 (IP56 on Request)
- + Mounting IMB3 (IMB35, IMV1 on request)
- + Insulated Bearing available on request
- + Shaft Grounding on request

<p>INDUSTRIES SERVED Industrial Gases: Compressors Mining: Compressors and Fans Pulp and Paper: Refiners</p>	<p>Steel Mills: Blowers, Compressors, Fans, Rod and Bar Mills Petroleum: Compressors Utilities: Fans, Pumps, Transmissions & Hydraulic Pack</p>	<p>NOTE + Non stock items, contact Fasco for availability, specifications and drawings.</p>
<p>All XR and XRH Power Drive units can be tailored for the individual customer. A wide range of selection options are available. Since 1913, Marathon Electric has been dedicated to providing customers with quality products for targeted applications from our own facilities to exacting standards with full engineering support.</p>		

FASCO RANGE AT A GLANCE

GENERAL INFORMATION

FASCO's is Asia Pacific's leading manufacturer and supplier of speciality FHP electric motors and pumps for all air movement, appliance and industrial applications. Our range includes:



C FRAME MOTORS (SHADED 2 POLE)

Shaded Pole AC Motor suitable for Domestic & Commercial Appliances.

Washing Machine Pumps, Fan Forced Oven Kits, Refrigeration, Heating & Ventilation Applications.

EVAPORATIVE COOLER PUMPS

Direct replacement, recirculating pumps for evaporative cooler applications. Designed to suit Australian conditions. Available in 4 sizes. A Flow Rate of 9.5l/s to 38l/s at a maximum head of 1600mm is obtainable using a 20mm hose.

5 SERIES ROUND FAN MOTORS (SHADED 4 POLE)

Widely used in the Refrigeration & Air movement market, with multiple mounting points to suit most applications.

55 SERIES SQUARE FAN MOTORS (SHADED 4 POLE)

Widely used in the Refrigeration & Air movement market with multiple mounting points (including foot) to suit most applications.

AXIAL FAN ASSEMBLIES

Used extensively in the Airconditioning, Refrigeration & Ventilation Markets. Design to suit Australian Conditions.

6 SERIES POOL & SPA MOTORS 'AQUADRIVE'

Pool and Spa Motors. Designed and developed in Australia to suit Australian, New Zealand and European conditions. With CE and TUV marks.

7 SERIES POOL & SPA MOTORS 'AQUADRIVE'

Pool and Spa Motors. Designed and developed in Australia to suit Australian, New Zealand and European conditions. With CE and TUV marks.

38, 48 & 56 FRAME MOTORS (AIR MOVEMENT)

Used extensively in the Airconditioning, Refrigeration & Ventilation Markets. Designed to suit Australian Conditions.

HEAVY DUTY, 48 & 56 FRAME MULTI PURPOSE MOTORS

Heavy duty rolled steel shell motors available in B56, Foot mount design. Applications include Air Compressors, Bricksaws, Evaporative Coolers & general purpose belt driven applications. Designed to suit Australian Conditions.

CABIN FANS

Designed in 12V & 24V DC to suit various applications including, trucks, tractors, buses, boats, aircraft & recreational vehicles.

DC BRUSH MOTORS (MULT PURPOSE)

Designed in 12V & 24V DC. For general purpose use in air movement, pumping and mechanical applications. Suits various applications including, trucks, tractors, buses, boats, aviation & recreational vehicles.

FAN DECKS AC BLOWERS

Used extensively in the Airconditioning & Ventilation Markets. Designed to suit Australian Conditions.

FAN DECKS DC BLOWERS

Designed in 12V & 24V DC for general automotive, caravan, boat and aircraft air movement applications, suits various applications including trucks, tractors, buses, boats, aviation & recreational vehicles.

ALUMINIUM SINGLE PHASE INDUSTRIAL MOTORS

Aluminium Body with a Single Phase Capacitor exceeds IEC and Australian/NZ standards, Permanent Split Capacitor.

ALUMINIUM (TOP MOUNT) THREE PHASE INDUSTRIAL MOTORS – MEPS 2 COMPLIANT

Aluminium Body, Removable feet. Frame sizes 80 to 132 (160 on Request). Available in 2/4/6 & 8 pole designs.

CAST IRON (TOP MOUNT) – THREE PHASE INDUSTRIAL MOTORS – MEPS 2 COMPLIANT

Frame sizes 80 to 355. Available in 2/4/6 & 8 pole designs. Regreasing nipples & thermistors fitted in 160M frame & above.

ACCESSORIES TO SUIT FASCO INDUSTRIAL RANGE

Replacement & Retro fit parts available to suit Fasco's Cast Iron & Aluminium range of motors.

EXHAUST FANS – CEILING, WINDOW, WALL AND SKYLIGHT

Suitable for use in various ventilation applications.

INLINE AXIAL FANS (AIR SHIFTER)

Suitable for transfer of Cool or Warm air from one room to another or exhausting air into the atmosphere.

DUCTED ACCESSORIES

A range of flexible ducting, grilles, branch take offs, louvre's and round diffusers.

DUCTED AIR TRANSFER/EXHAUST KITS & ROOF EXHAUST KITS

Suitable for use in ventilation applications requiring movement of Cool or Warm air from one room to another or exhausting air to the atmosphere.

FAN BLADES

Aluminium & Plastic. Available from 100 to 300mm diameters that suit most Refrigeration and Ventilation applications.

ACCESSORIES AND MOUNTING KITS

Various mounting kits, rainshields, grilles & rings available to suit 8 series HVAC motors, 5 series round & 55 series square shaded pole motors.

ELECTRIC MOTORS EVAPORATIVE COOLER PUMPS FAN DECKS VENTILATION PRODUCTS FAN BLADES FANS A
 PHASE MOTORS ELECTRIC MOTORS EVAPORATIVE COOLER PUMPS FAN DECKS VENTILATION PRODUCTS F
 ELECTRIC MOTORS FAN BLADES FAN DECKS ELECTRIC MOTORS EVAPORATIVE COOLER PUMPS FAN DECKS VEN
 AN DECKS VENTILATION PRODUCTS FAN BLADES FANS ACCESSORIES PUMPS VENTILATION PRODUCTS 3 P
 ELECTRIC MOTORS EVAPORATIVE COOLER PUMPS FAN DECKS VENTILATION PRODUCTS FAN BLADES FANS A
 PHASE MOTORS ELECTRIC MOTORS EVAPORATIVE COOLER PUMPS FAN DECKS VENTILATION PRODUCTS FAN E



FASCO Australia Pty Ltd

1/14 Monterey Road
 Dandenong South VIC 3175
 Australia

T. + 61 3 8787 2100

F. + 61 3 8787 2173

www.fasco.com.au



Quality Endorsed Company
 ISO 9001 Lic 21276
 514 OK204



Certified Environmental Management
 ISO 14001 Lic 20152
 514 OK204



GE Commercial Motors
 By REGAL-BELOIT



Design, data, dimensions and specifications are all subject to change without notice.

